

INSTRUCTION SHEET

Refri-Shield™ Liquid Level Gauge



CONTENTS

- 1.1 Overview
- 2.1 Warnings
- 2.2 Components & Tools
- 3.1 Installation
- 3.2 Electronics Wiring
- 4.1 Retrofit Installation
- 5.1 Contact & Notices

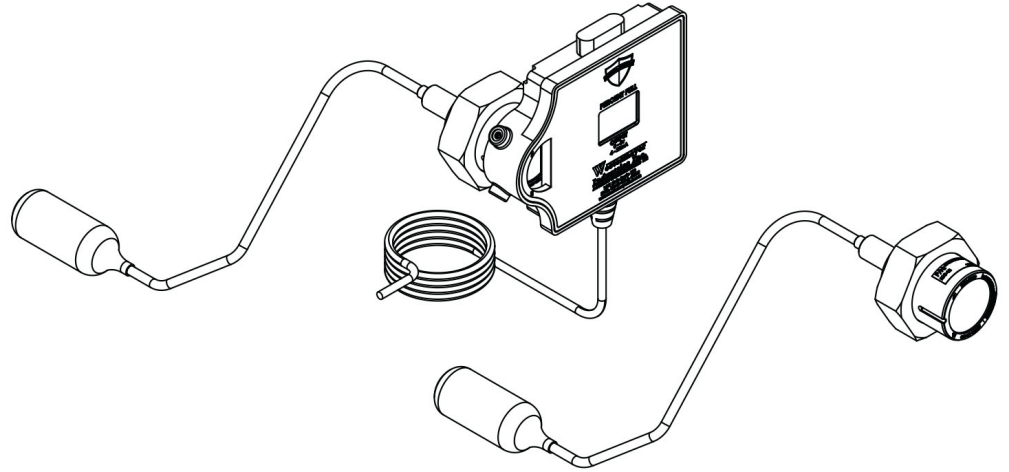

1.1 OVERVIEW

Introduction

The "RSG" liquid level gauge is the introductory product to the **Refri-Shield™** line of level detection components.

Electronic models feature a backlit LCD readout and can be serviced and replaced by two set screws without pumping the system down. All models include a bubble level on top of the outer housing to assist in proper installation.

The gauge itself is a Rotolock sight glass housing utilizing a PTFE gasket for superior seal and minimized leak potential. Conversion kits are available for mechanical models to upgrade to full electronics, as well as retrofit kits to install the RSG on older 4-bolt flange receivers.

Available Models

MODEL	VESSEL OD	FLOAT SWING
RSG-8(E)*	8 5/8"	4 3/4"
RSG-10(E)	10 3/4"	6"
RSG-12(E)	12 3/4"	7"
RSG-14(E)	14"	8 1/2"
RSG-16(E)	16"	9 1/2"
RSG-18(E)	18"	10 1/2"
RSG-20(E)	20"	11 1/2"
RSG-24(E)	24"	13 1/2"

*Add "E" for electronic model. (ex. RSG-8E)

Parts & Accessories

DESCRIPTION	P / N
Electronic Housing	RSG-1HE
Alignment Housing (Non-Electronic)	RSG-1H
Four-Bolt Retrofit Kit	190-004K

Features

- 1 3/4" Rotolock sight glass design with easy-to-read liquid level indicator
- Watertight electronic housing made of Dupont Zytel glass reinforced polymers (on mechanical-only models, this is a blank housing for alignment purposes only)

Electronics Specifications

- 12 foot cable
- 12V AC or DC
 - AC accepted range: 10V-14V
 - DC accepted range: 11.5V-14V
- Amp draw: 12V supply
 - 70mA-100mA (depending on relay state)
- 12V Common
 - Relay Common
- 0V-5V out +/- 0.1V
 - Minimum accepted load: 100 ohms
 - 4mA-20mA out
 - Maximum load for full 20mA: 400 ohms
- Dry-contact relay set at 20%
 - Relay contact rating: 2 amps
- Electronic Operating Temperature
 - 40°C to 85°C (-40°F to 185°F)
- Factory Calibrated
- Pressure-boundary components listed in accordance with UL-207

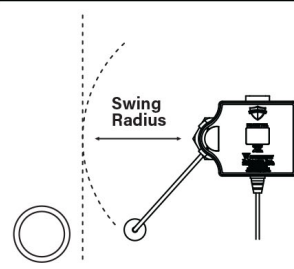

See "Float Swing" dimension to insure gauge is installed clear of all connections or internal components.

2.1 WARNINGS

Warning

Improper installation or misuse of this product may cause serious personal injury or damage to equipment and property.

THESE INSTRUCTIONS ARE PREPARED TO ASSIST QUALIFIED PERSONNEL TO SERVICE LIQUID PRESSURE VESSEL EQUIPMENT. CONSUMERS ARE NOT QUALIFIED TO PERFORM THE INSTALLATION DESCRIBED BELOW.

Is this gauge right for your application?

Gauges should only be installed in applications recommended by Westermeyer Industries. Verify that the gauge is suitable for your application prior to attempting installation.

- The gauge, gasket, Rotolock swivel nut, and mounting adapter (if applicable) must be constructed of materials compatible with the liquid to be measured and the service environment.
- The float, sight glass, Rotolock connection, and mounting adapter (if applicable) must be adequately rated for your specific pressure and temperature service environment.

The Westermeyer Industries "RSG" series floats and gaskets are certified for HFC, HCFC, and HFO refrigerants at pressures up to 700 PSIG.

Is this gauge the proper size?

As a general rule, the float when installed should pivot on the horizontal centerline of the tank. Float swing dimension (measured from the float pivot point to the end of the float) should be proportional to the inside tank height. The gauge will not display accurate readings if the float-arm is the incorrect length for the diameter of your vessel. **Contact Westermeyer Industries for the proper float-arm length for your application.**

Gauge removal warning

Should it appear necessary to remove the gauge from the tank, do not attempt removal unless under competent supervision with all due precautions taken against the hazards of released liquid or high-pressure and/or flammable gas.

EVEN IF A GAUGE REGISTERS EMPTY, THE TANK MAY CONTAIN HIGH PRESSURE AND FLAMMABLE GAS. A HAZARD OF FIRE OR EXPLOSION MAY EXIST IF PROPER METHODS ARE NOT USED WHEN REMOVING OR INSTALLING THE GAUGE OR GASKET. REPLACE GASKET IF GAUGE IS REMOVED. DO NOT REUSE GASKET.

2.2 COMPONENTS & TOOLS

Components (Included)

- A Refri-Shield Level Gauge
- B Rotolock Swivel Nut
- C Refri-Shield Housing
- On non-electronic mechanical models, this is a blank for alignment purposes only.*
- D PTFE Gasket (part number 100-024)
- E Retrofit Gasket (part number 100-038A)*
- F Rotolock Spud Connector*
- G 4-Bolt Retrofit Plate*
- H 5/16" Socket Head Screws (4) with washers*

Tools (Not Included)

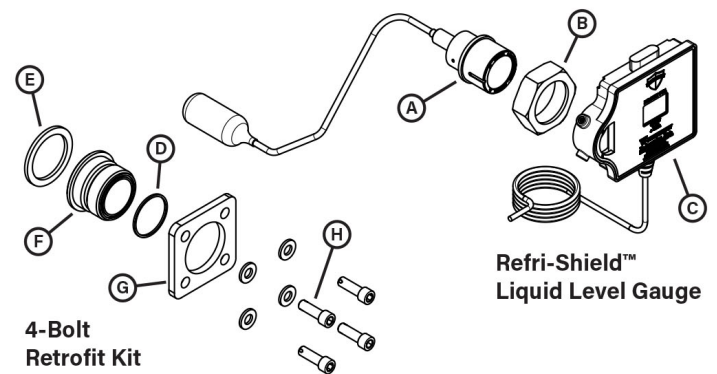

- 1/16" Hex Key
- 1/4" Hex Key*
- 1 3/8" Wrench
- Torque Wrench
- "Nylog" gasket adhesive*
- Acetone for flange-surface cleaning*

*Retrofit Kit Only

3.1 INSTALLATION

Preparation

These steps may not apply to new installations, but are necessary precautions for gauge installation or service on previously operating systems.

1. Isolate the receiver from the system using the valves on the inlet and outlet of the receiver.
2. Using an evacuation pump, evacuate all refrigerant from the receiver.
3. Check to make sure the receiver has no internal pressure before servicing.

Installation

1. Take the supplied PTFE gasket (part number 100-024) and snap it into the groove on the face of the receiver's Rotolock spud connection.
2. Carefully guide the float arm bulb-first through the fitting, ensuring that the Refri-Shield housing hangs to the right of the sight glass and the float arm swivels to the left. (See example)

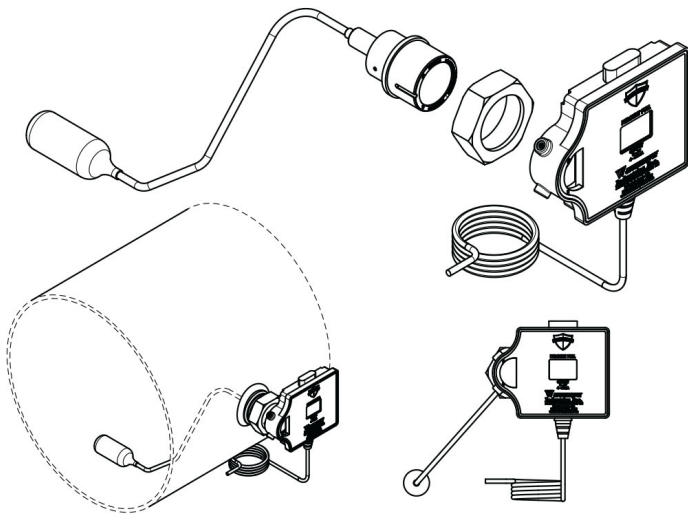

3. Finger-tighten the Rotolock swivel nut, using the bubble-level on the Refri-Shield housing to ensure that the gauge is aligned and leveled correctly. (Level alignment is essential for accurate liquid level metering.)
4. With one hand, secure the Refri-Shield housing, holding it steady in level position. With the other hand, torque the Rotolock swivel nut to 65 ft lbs to ensure proper seal.
5. **Non-Electronic Mechanical Models:** using a 1/16" hex wrench, loosen the two set screws on the left side of the Refri-Shield housing. Slide the housing away from the sight glass to remove.
6. Unit is now ready for service.

3.2 ELECTRONICS WIRING

1. Using the bubble-level on the Refri-Shield housing, ensure that the gauge is level to the installed vessel.
2. Using the supplied wiring diagram connect the Refri-Shield electronic level gauge to the power supply and rack controller.
Note: (For Emerson E2, see suggested setup below)

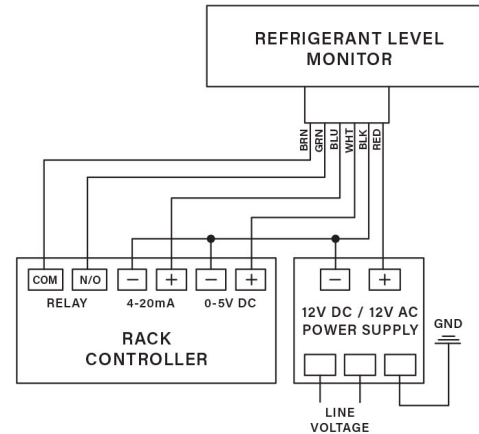

- a. Connect voltage (0-5 VDC, WHITE and BLACK) OR connect current (4-20 mA, BLUE and BLACK) to main controller.
 - b. Connect relay to controller with GREEN to relay and BROWN to common.
 - c. Apply power to RED(+) and BLACK(-) wires.
3. Switch on the power supply to power up the unit. LCD display will blink "50" for 5-15 seconds during power-up, then flash "C" for a split second, indicating factory calibration.
 4. The unit is preset to power up into ALARM MODE.

Once the receiver begins to fill, the relay contacts will open after holding AT OR ABOVE 20% capacity for TEN CONSECUTIVE SECONDS.

This will deactivate ALARM MODE.

During operation, the relay will trip and activate ALARM MODE if the liquid level falls BELOW 20% capacity for TEN CONSECUTIVE SECONDS.

Holding ABOVE 20% for TEN CONSECUTIVE SECONDS will deactivate ALARM MODE.

5. Unit is now ready for service.

Suggested Emerson E2 Setup

- Wired 0-5V output using 12V power from the input board and looping negative to input 0V
 - ▷ Red to 12V
 - ▷ Black to assigned input 0V
 - ▷ White to assigned input SIG
- Programmed input set-up as "Refrig Level" in the type selection

4.1 RETROFIT INSTALLATION

Preparation

These steps may not apply to new installations, but are necessary precautions for gauge installation or service on previously operating systems.

1. Isolate the receiver from the system using the valves on the inlet and outlet of the receiver.
2. Using an evacuation pump, evacuate all refrigerant from the receiver.
3. Check to make sure the receiver has no internal pressure before servicing.

Installation

1. Remove the protective film from the back of the Rotolock spud connector. **Caution: to avoid damaging the serrated finish and threads, do not use a sharp object.**
2. Take the supplied PTFE gasket (part number 100-024) and snap it into the groove on the face of the supplied Rotolock spud connection.
3.
 - a. Using a 1/16" hex wrench, loosen the two set screws on the left side of the Refri-Shield housing.
 - b. Slide the housing away from the sight glass to remove.
 - c. Remove the Rotolock swivel nut from the gauge unit.
4. On the receiver, clean the face of the senior flange using acetone to ensure the surface is dirt free. Apply a small bead of "Nylog" adhesive to the flange surface and secure the retrofit gasket (part number 100-038A) to the face of the flange. After securing the gasket, apply "Nylog," to the outer-facing surface of the gasket as well.
5. Slide the four-bolt retrofit plate over the Rotolock spud, then guide the float arm bulb-first through the Rotolock fitting.
6. Holding the plate and Rotolock spud together with the gauge sightglass, carefully guide the float arm through the senior flange and into the receiver, ensuring that the float arm swings to the left of the flange for proper orientation.
7.
 - a. Holding the Rotolock spud and 4-bolt plate in place against the senior flange, thread the socket screws with washers into the flange and finger tighten.
 - b. Using a torque wrench with a 1/4" hex key, tighten the screws in a criss-cross pattern to 10 ft lbs each.
8.
 - a. Replace the Rotolock swivel nut and finger tighten onto the Rotolock spud connection.
 - b. Slide the Refri-Shield housing back onto the face of the gauge, aligning the notch inside the housing with the groove on the left side of the sight glass unit.
 - c. Using a 1/16" hex wrench, tighten the set-screws on the left side of the Refri-Shield housing, securing it in place. *(Set screws should align with the two divots on the sightglass housing.)*

9. Use the bubble-level on the Refri-Shield housing to ensure that the gauge is aligned and leveled correctly. *(Level alignment is essential for accurate liquid level metering.)*
10. With one hand, secure the Refri-Shield housing, holding it steady in level position. With the other hand, torque the Rotolock swivel nut to 65 ft lbs to ensure proper seal.
11. **Non-Electronic Mechanical Models:** *Once leveled and oriented correctly, use a 1/16" allen wrench to loosen the two set screws on the left side of the Refri-Shield housing. Slide the housing away from the sight glass to remove.*
12. Unit is now ready for service.

